

***FORELL Intelligent Agents Technology (FIAT) – The Next Generation Enabler
for
PRODUCTIVITY AMPLIFICATION***

BACKGROUND

There are two categories of agent applications:

1. **Agent-based Systems**. In this case agents are embedded in applications, making decisions on behalf of applications and users. These decisions are based on a set of rules, criteria, operational thresholds, and objectives that can change as the environmental state evolves and the operational tempo changes. Agents applied in this manner provide a level of automation that reduces operator workload. They can perform consistently 24/7, providing a higher degree of accuracy and reliability, especially under stress conditions. Agents can thus be viewed as facilitators that reduce workload, improving system performance.
2. **Agent-based Simulation** focuses on the use of agents in generation of an operational simulation for the purpose of observing and analyzing system behaviors and complexities for improving system performance. For example, system requirements definition and resultant optimized functional allocation of these requirements directly benefit from such simulation.

I. FORELL INTELLIGENT AGENT-BASED SYSTEMS

FORELL Intelligent Agents, patent pending, bring a capability that is akin to quantum brain capability, tapping into a ***higher intelligence for quicker reasoning and decision processing***. The human brain is a



marvel in that it has a tremendous cognition or memory capability. The average human being uses only a fraction of this power. FORELL Intelligent Agents mimic this human brain capability using ***quantum brain theory***, unleashing this unsurpassed power to enable the Warfighter to deal with large amounts of data, complex relationships, and ambiguity in decision making. Quantum brain theory suggests that neurons communicate through their sensitivity to quantum waves causing state changes. The brain consists of an incalculable number of neurons that can be partitioned into trillions of objects that the brain can ***recognize in the face of ambiguity***.

The following example demonstrates the ability of the brain to ***quickly*** recognize the meaning of a phrase in the face of ambiguity: “I cdnolt bveiee that I cluod aulacly usdnatnrnd waht I was rdanieg. The phaonneal pweor of the hman mnid! Aoccdrnig to a rscheearch at Cmabrigde Uinevtisy, it deosnt mttar in waht oredr the ltteers in a wrod are, the olny iprmoatnt tihng is taht the frist and lsat ltteer be in the rghit pclae.” How long did it take you to resolve ambiguity in these words? The brain has enormous

cognitive ability and resolves ambiguity through *association with that which it has stored in “prior memory”*. In this example, the correct spelling of these words already exists in your memory. The brain is able to recognize each word by its length and the first and last character. These are the characteristics (features) of the words.

In order for the brain to associate meanings, objects are identified by their characteristics rather than their specificities. The neurons states can be viewed as a tapestry of many overlapping objects, the union of these objects representing a *knowledge base*. As the sensory preceptors change the neuron states through quantum waves, objects characteristics are identified and cognition occurs through the association with objects with like kind characteristics. The brain “takes in” and observes constantly and the objects “in focus” change with the mind set’s objectives, i.e., the brain *adapts*, bringing to the fore that which it deems most important. The importance of any one or more objects is established through sets of threshold criteria associated with time dependent objectives. FORELL Intelligent Agents operate much like a quantum brain, providing quick cognition capability for *improved Situational Awareness and improved decision processing*. This capability is provided through agents that support autonomous decision processing through rules that are created in an offline simulation mode and are then embedded in the operational system.

II FORELL INTELLIGENT AGENT-BASED SIMULATION

FORELL’s Agent-based simulation capability provides for *quick* generation of Artificial Intelligence (AI) rules that are optimized for optimal performance in the objective system and definition of the features for environment monitoring. These capabilities provide a sound *Automation Foundation for PRODUCTIVITY AMPLIFICATION*.

FORELL Intelligent Agents are implemented through Services with standard Application Program Interfaces (APIs) that support execution and access to domain specific Feature Extraction (environment characteristic / feature definition) and rule files. These Intelligent Agent Services and the feature and rules data, implemented through mission specific adaptation files, reside in the service-oriented Open Architecture Framework, as shown in Figure 2.

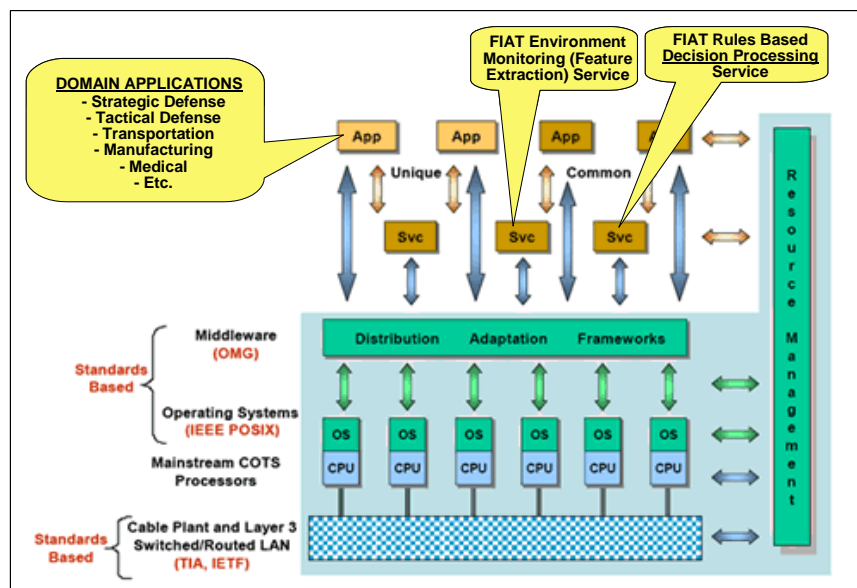

Figure 2 – FORELL Intelligent Agent Services in the Open Architecture Framework

1. Environment Monitoring Service (EMS)

FORELL Intelligent Agent Feature Extraction (FE) Capability identifies those environmental characteristics that contribute to *quick recognition capabilities supporting Situational Awareness*. FE reduces the large environmental state spaces to only that which is required using characteristics / features (sensor inputs), reinforcement learning techniques and domain specific performance objectives / goals. The Environmental Monitoring service is provided as a *Service* in the Open Architecture Framework with a standard Application Program Interface (API) for execution. This approach provides system flexibility and extensibility, *reducing overall development cost*.

2. Rules Based Decision Processing Service (DPS)

DPS uses FORELL Intelligent Agent Classifier that operates on decision rules that are created in the simulation off-line mode. These rules are tailored to meet domain specific decision processing goals / Measures of Effectiveness (MOEs). *FORELL's Classifier is UNIQUE* in that the initial set of rules is modified to optimize performance using reinforcement learning techniques. These rule files are domain and situation specific and are *executed in the context of the operational scenario*. Intelligent agents are to “sense” the context through the Environmental Monitoring capability and will “know” which rules to execute. Rules are implemented as adaptation files in the operational system. New rule files to satisfy new or different objectives are readily created and inserted in the operational system, providing for system flexibility and extensibility. Rules are human readable and are in the form of “if < > then < >” statements. Rules so generated are *deterministic and are testable*. The ability to quickly generate optimized rules for use in operational systems and the ability to tailor these rules for specific mission objectives provides software-based war-fighting capabilities quickly “without time-consuming system rebuilds”.

PRODUCTIVITY AMPLIFICATION

Many DoD programs have PRODUCTIVITY AMPLIFICATION requirements to reduce “manning requirements” in order to *reduce program life cycle cost*. Programs attempt to satisfy these productivity amplification requirements through automation. Automation can be provided through automated hardware or equipment or software that supports operator tasks and their related decision processing. Intelligent agents using environmental definitions and decision processing rules reduce operator workload 24/7, requiring fewer personnel for performing tasks and thereby reducing program life cycle cost. Automation implemented through intelligent agents also increases operators’ quality of life. It reduces risk in times when operators are required to work under extremely stressful conditions, such as, war conditions with insufficient rest or sleep.

Software automation tools are commonly being marketed as Artificial Intelligence “engines” or inferencing engines. As such i.e., “AI engines”, they leave a gap in automation for productivity amplification. They fail to provide the necessary domain specific rules that make the automation work. *FORELL Intelligent Agent Technology fills that gap*. Using our agent-based simulation capability, rules are generated and optimized to satisfy stated system performance objectives / goals. Rules can be generated to support different operator tasks or different rules can be generated for the same task but for different objectives. The FORELL Intelligent Agent Technology thus provides for the development of flexible, tailorable systems to satisfy mission objectives. This technology also provides the capability to generate rules for decision processing, *providing the automation facilities for productivity amplification*.

Contact Mr. Lary Smith at 714-690-7720 or 202-251-0021 (cell) for further information.